

MODEL 560 DC BRUSHLESS THRUSTERS

Developed from Tecnadyne's highly successful Model 520 thruster, of which over 1,450 units have been sold over a 20 year period, the Model 560 develops 70% more thrust and is 30% more efficient yet is no larger in size. Now a full 1hp thruster, the Model 560 produces 17kg forward thrust and 10kg in reverse. The Model 560 is ideally suited for mid sized and light work ROV's, AUV's and other critical subsea applications.



As with all Tecnadyne thrusters, the propeller of the Model 560 is magnetically coupled. With this design, a magnet array in the hub of the propeller is driven by a matching magnet array attached to the drive motor. By eliminating the rotating drive shaft and shaft seals that always seem to leak over time, the Model 560 achieves extremely high reliability. Additionally, the magnetic coupling will ratchet if overloaded, preventing damage caused by objects jammed in the propeller. And since the water lubricated propeller bearings are external to the pressure housing, they can be easily replaced in several minutes.

Employing a high RPM, low inertia DC brushless motor, coupled to a 6/1 ratio planetary gearset, the Model 560 delivers maximum reliability, high efficiency and high power in an extremely compact, lightweight and easy to maintain package. The stainless steel propeller, available in both right and left hand rotations, combined with a custom designed Kort nozzle, give the Model 300 extremely high Bollard thrust and open water efficiency.

For depths to 1,000 meters and optionally to 2,500 meters, the power and control electronics are housed within the hard anodized aluminum motor casing, greatly simplifying the installation and electrical interface. For full ocean depth rating, the electronics are installed in a remote, one atmosphere housing (either the customer's housing or one supplied by Tecnadyne) and the thruster is oil filled for pressure tolerance.

The Model 560 is available for operation at voltages from 24vdc to 330vdc (150vdc standard) supplied by a well filtered battery bank, rectified and filtered AC or a DC power supply. In addition to the main power, the thruster requires isolated 12vdc instrumentation power and a +/-5v analog speed and direction control signal. Alternately, a full servo RS232 or RS485 input controller is available but this must be installed in a remote, one atmosphere housing. Please refer to the Tecnadyne website for detailed installation and interface instructions.

The standard depth rating of the Model 560 is 850 meters - 2,500 meters and oil filled, full ocean depth are available options. Customer specified subsea connectors and cables, stainless steel or titanium housings, custom mountings and full retrofit compatibility with the Model 520 thruster are also available.

MODEL 560 SPECIFICATIONS

Bollard Output

38lbf (17.3kg) forward
22lbf (10kg) reverse
w/ either right hand or
left hand stainless steel
propeller

Input

150vdc, 6.5A power
(975 watts at alternate
voltages)
+12v, 200mA isolated
instrumentation power
+/-5v analog speed
command

Weight

4.2lb (1.9kg) in air
3.0lb (1.4kg) in water

Depth Rating

2,800ft (850m) standard
8,000ft (2,500m) and
full ocean depth (oil
filled) optional

(1,000m & greater depth subject to
US Govt. export approval)

MODEL 560 DC BRUSHLESS THRUSTERS

Part Number: 560 -

- (22-26vdc) 024, (28-32vdc) 030
- (40-44vdc) 044, (46-50vdc) 048
- (56-60vdc) 060, (70-75vdc) 075
- (95-105vdc) 100, (125-135vdc) 130
- (145-155vdc) 150, (190-210vdc) 200
- (220-240vdc) 230, (250-280vdc) 260

- Cn (SeaCon MCIL-6M w/ cable of n meters)
- In (SeaCon IL-6M w/ cable of n meters)
- Ln (SeaCon LMG-6FS w/ cable length of n meters)
- Mn (SeaCon LMG-6MP w/ cable length of n meters)
- X (Customer specified connector)

- 850 (850m depth)
- 2500 (2500m depth)
- OFRE (oil filled remote electronics)

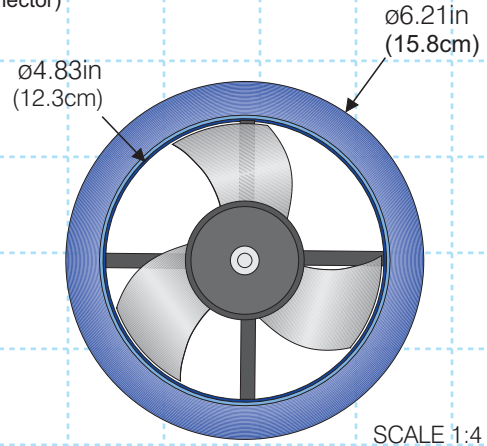
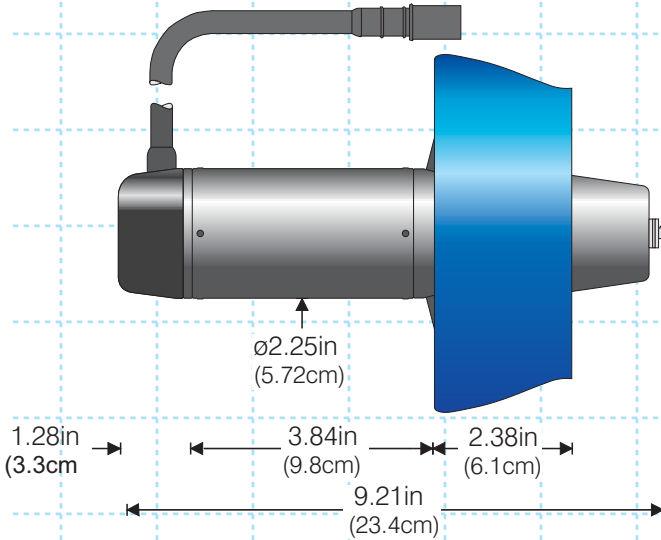

Note: Due to motor tolerances, voltage required to achieve rated Bollard thrust can vary +/-5%
Specifications subject to change without notice

