

MODEL 540 DC BRUSHLESS THRUSTERS

The Model 540 is the tunnel thruster version of the Model 520 & 560 ducted thrusters, of which Tecnadyne has delivered over 1,400 units to customers worldwide. The Model 540 fits within a tunnel duct of 15.2cm inside diameter. Since it produces the same Bollard thrust in both forward and reverse directions, the Model 540 is ideally suited as a lateral or vertical thruster on mid-size AUV's and on hydrodynamic ROV's.

The precision stainless steel propeller of the Model 540 is magnetically coupled using a design perfected by Tecnadyne. With this design, a magnet array in the hub of the propeller is driven by a matching magnet array attached to the drive motor. By eliminating the rotating drive shaft and shaft seals that always seem to leak over time, the Model 540 achieves extremely high reliability. Additionally, the magnetic coupling will ratchet if overloaded, preventing damage caused by objects jammed in the propeller. And since the water lubricated propeller bearings are external to the pressure housing, they can be easily replaced in several minutes.

Employing a high RPM, low inertia DC brushless motor, coupled to a 6/1 ratio planetary gearset, the Model 540 delivers maximum reliability, high efficiency and high power in an extremely compact, lightweight and easy to maintain package.

For depths to 1,000 meters and optionally to 2,500 meters, the power and control electronics are housed within the hard anodized aluminum motor casing, greatly simplifying the installation and electrical interface. For full ocean depth rating, the electronics are installed in a remote, one atmosphere housing (either the customer's housing or one supplied by Tecnadyne) and the thruster is oil filled for pressure tolerance.

The Model 540 is available for operation at voltages from 48vdc to 330vdc (150vdc standard) supplied by a well filtered battery bank, rectified and filtered AC or a DC power supply. In addition to the main power, the thruster requires an isolated +/-5v analog speed and direction control signal and 12vdc instrumentation power. Alternately, a full servo RS232 or RS485 input controller is available which, due to its size, must be installed in a remote, one atmosphere housing. Please refer to the Tecnadyne website for detailed installation and interface instructions.

The standard depth rating of the Model 540 is 850 meters. 2,500 meters and full ocean depth with remote one atmosphere electronics is an available option. Remote electronics options include the extremely compact Tecnadyne controller module or larger, full servo brushless or sensorless units. For applications requiring extremely low noise, Tecnadyne offers an optional remote linear drive. Customer specified subsea connectors and cables, stainless steel or titanium housings and custom mountings are also available.



MODEL 540 SPECIFICATIONS

Bollard Output

21lbf (9.5kg) forward
21lbf (9.5kg) reverse

Input

150vdc, 3A power
(450 watts at alternate
voltages)
12vdc, 200mA isolated
instrumentation power
+/-5v analog speed
command

Weight

4.2lb (1.9kg) in air
3.0lb (1.4kg) in water

Depth Rating

2,800ft (850m) standard,
8,000ft (2,500m) and
full ocean depth (oil
filled) optional

(1,000m & greater depth subject to
US Govt. export approval)

MODEL 540 DC BRUSHLESS THRUSTERS

Part Number: 540 -

- (44-52vdc) 048
- (65-75vdc) 070
- (110-130vdc) 120
- (140-160vdc) 150
- (190-210vdc) 200
- (250-280vdc) 260
- (300-330vdc) 300

- Bn (LPMBH-6MP / LPMIL-6FS w/ cable of n meters)
- Ln (SeaCon LMG-6FS w/ cable length of n meters)
- Mn (SeaCon LMG-6MP w/ cable length of n meters)
- X (Customer specified connector)

- 0850 (850m depth)
- 2500 (2500m depth)
- OFRE (oil filled remote electronics)

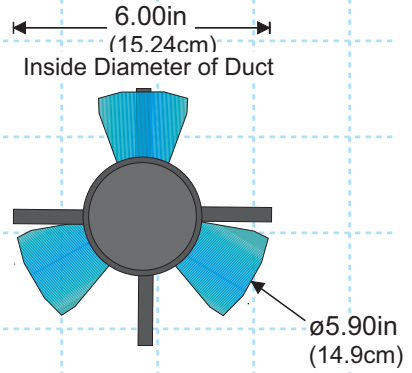
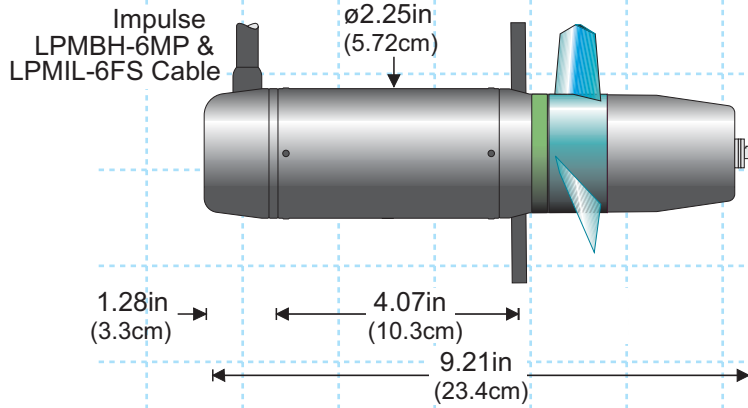

Note: Due to motor tolerances, voltage required to achieve rated Bollard thrust can vary +/-5%
Specifications subject to change without notice

